

# THE LATEST IN SPREADING TECHNOLOGY

# THE AGRISPREAD

# LINKAGE BELT SPREADER

For the first time, a three-point linkage belt spreader with the capacity and ability to spread all materials.



**LANDACO**  
EQUIPMENT

**THE LATEST IN SPREADING TECHNOLOGY**

# THE AGRISPREAD LINKAGE



## Invest in the latest spreading technology available.

**The Agrispread linkage belt spreader offers farmers the benefit of being able to spread a much wider range of products, with unbeatable performance and maneuverability.**

The **LANDACO Agrispread** is the ideal low maintenance linkage spreader designed to spread the full range of materials available to all facets of farming, from the lightest granulates, powders and manures to the heavier gypsum and damp lime. Agrispread linkage models are available in 1500, 2000 & 3000 series. The **Landaco Agrispread** will effectively spread lime, gypsum, urea, super, cow manure, chicken litter, MAP, DAP, dolomite, seeds and much more. The Agrispread range of spreaders have unique features, which have been tried and tested over many years and proven to be superior to other linkage machines in this category. The Agrispread linkage spreader range are available with a ground drive unit; the conveyor is driven by a rubber tyre which hydraulically engages and disengages with the tractors rear wheel. The drive has a multi-position frame that will allow the drive system to match up to different tractor tyres and axle positions. The ground drive unit gives the operator the benefit of selecting and changing speeds to suit the terrain, without affecting the application rate.

**The ground drive unit can easily be seen from the tractor cabin giving you peace of mind that the application of your fertilizer is being applied evenly, consistently and proportionally to ground speed.**

The Agrispread features an 800mm wide continuous cleated PVC conveyor, and is fitted with our proven positive belt drive system, with no chains or moving parts exposed to the elements. The mechanical drive system is sealed, grease packed and enclosed to keep it clean and virtually maintenance free. The conveyor drive is hydraulically controlled on and off, with the belt stopping as soon as the ground-drive unit is disengaged. The cleated conveyor eliminates the need for agitation, so the products you spread are metered evenly without grinding or crushing.

**The Agrispread has heavy-duty twin 700mm diameter hydraulic spinners with high efficiency casting vanes as standard, for the fullest and most even spreading pattern.**

The recommended spinner RPM range is 500-850rpm. The spinner assembly is removable, allowing the spreader to be used for feeding grain, laying gravel on roads, distributing material in rows or simply shifting material from A to B. With the spinner assembly removed the spreader can be readily fitted with optional grain augers, feeding chutes and side delivery conveyors.

### Benefits:

- **Compact Design** – Maneuverability & ground clearance
- **Proven Belt Feed System** – Spread a range of materials evenly
- **Ground Drive** – Proportional application
- **Adjustable spinner speeds** – Vary spread widths to suit requirements
- **Single quick-set door**– Simple to select application rate
- **Wide spread for all materials**– Less fuel, less passes, less compaction

For the first time, a three-point linkage belt spreader with the capacity and ability to spread all materials.



With the ground drive Landaco Agrispread Linkage belt spreader, selecting an application rate and calibration is made easy with the Agrispread excel based quick set calibration program. The products density and the desired spread width are entered including a door height and displayed is your application rate per hectare. To know a products density often the supplier will have a product information sheet available or Landaco have available a product density scale tool.

#### All LANDACO Agrispread linkage belt spreaders feature:

- **Chassis:** Robust folded section chassis for stability and long working life.
- **Drive Roller:** Crowned & taper locked to shaft for continuous drive.
- **Tracking Rollers:** Self cleaning and automatically maintains correct working line for conveyor.
- **Conveyor:** Top quality cleated PVC, 800mm continuous belt.
- **Twin Spinners:** Large 700mm spinners with advance designed vanes to give the widest, most even spreading pattern possible. Spreads urea with exceptional accuracy.
- **Conveyor Drive:** Fully enclosed chain reduction.
- **Rear Door:** Full width 700mm x 200mm with a quick set door latch for fast setting and accurate free flow of material.
- **Removable Spinner Assembly:** Allows controlled dumping, trail laying and the attachment of additional equipment such as augers and conveyors.
- **Visibility:** The Agrispread range is fitted with viewing window to increase operator awareness of low material level.
- **Options:** A range of options are available including Hydraulic Over-Drive, Drip Line Applicators, Side Chutes, Tarpaulin and Ridge Pole, Foam Markers (single or double), Seed and Trace Element Dispensers, Electronic Field and Material Monitors and Electronic Weight Scales.
- **Warranty:** All Agrispread spreaders are covered by a 12 month (1 year) warranty.

## “THE SPREADING ADVANTAGE”

Spread what you want – where you want – when you want



### AGRISPREAD LINKAGE RANGE

Agrispread	LS1500	LS2000	LS3000
Hopper Capacity Kg's	1500	2000	3000
Hopper Capacity Ltr	1250	1800	2800
Length (mm) - A	1800	1900	1820
Length (mm) - B	1800	2260	2700
Height (mm) - C	1400	1430	1650
Fill Opening LxW (mm)	1100x1630	1350x2200	1500x2600

### Working Spread Widths

Std. 700mm MPS	6-34	6-34	6-34
Max. Spinner Speed	950rpm	950rpm	950rpm
Linkage Category	I & II	II	II

**Price: \$**

\_\_\_\_\_

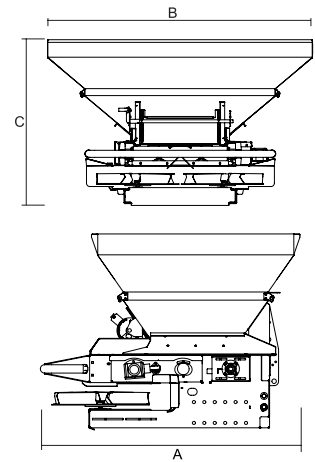

*All dimensions are accurate at time of publication.  
We reserve the right to change without prior notice.*

### Options available:

- Bin Extension Kits
- Flip-Tarp Hopper Covers
- Hydraulic-Electronic Control – Conveyor & Spinners
- Variable Rate and Touch Screen Controllers
- Weight Scales
- Auto-Hydraulic Rear Door
- Integrated Seed & Trace Element Dispenser
- Drip-line Spreading Attachment
- Folding Access Ladders
- Stainless Steel Components
- Trailing & Ute mount Kits
- Tail lights and night work lights

	LS1500	LS2000	LS3000
Bin Extension Kits	X	✓	✓
Flip-Tarp Hopper Covers	X	✓	✓
Hydraulic-Electronic Control – Conveyor & Spinners	X	✓	✓
Variable Rate and Touch Screen Controllers	X	✓	✓
Weight Scales	X	✓	✓
Auto-Hydraulic Rear Door	X	✓	✓
Integrated Seed & Trace Element Dispenser	X	✓	✓
Drip-line Spreading Attachment	✓	✓	✓
Folding Access Ladders	X	✓	✓
Stainless Steel Components	X	✓	✓
Trailing & Ute mount Kits	X	✓	✓
Tail lights and night work lights	✓	✓	✓

### Get the spreading advantage

With the rising fertiliser costs, you require choice and options when it comes to selecting products you can apply to enhance your productivity. Don't be limited by European thinking and design that locks you into certain types of fertilisers. The choice is simple. Either purchase a gravity fed linkage spreader which will only spread granular products OR invest in the **LANDACO Agrispread Linkage belt spreader**, which will spread a much wider range of materials and outperform other spreaders. Experience counts – with over thirty years in the spreader design and manufacturing industry, Landaco is a front runner in Australian design and innovation on a world platform. You will receive continual professional results with the easy-to-operate **LANDACO Agrispread**.

**The belt spreader every farmer can afford to have on their farm.**

## “THE SPREADING ADVANTAGE”

Spread what you want – where you want – when you want